

INSTALLATION & OPERATING INSTRUCTIONS

FOR YOUR SAFETY

If you smell gas:

1. Open windows and door.
2. Don't touch electrical switches.
3. Extinguish any open flame.
4. Turn off the gas supply at the source.
5. Contact a qualified person.

FOR YOUR SAFETY

Do not store or use gasoline or other flammable vapors and liquids in the vicinity of this or any other appliance.

WARNING

Improper installation, adjustment, alteration, service or maintenance can cause injury or property damage. Refer to this manual. For assistance or additional information consult a qualified installer, service agency or the gas supplier.

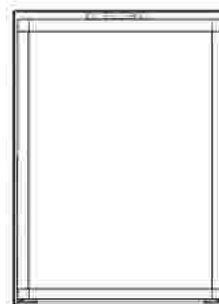

RM2356

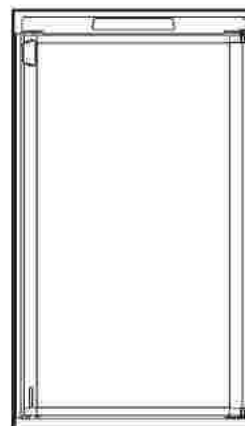

**RM2456
RM2556**

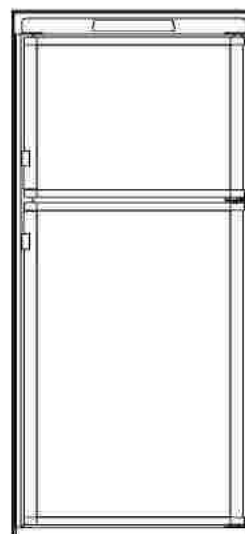

**RM4606
RM4806**

CONTENTS

INSTALLATION INSTRUCTIONS	3
GENERAL INFORMATION	3
PACKAGING	3
VENTILATION REQUIREMENTS	3
CLEARANCES	3
DIMENSIONS	4
INSTALLING THE REFRIGERATOR	5
SECURING THE REFRIGERATOR	5
CONNECTIONS	7
RE-HINGING THE DOOR	8
MOUNTING THE DOOR PANEL	8
REFRIGERATOR REMOVAL	8
OPERATING INSTRUCTIONS	9
QUICK START OPERATION	9
CHANGING FUNCTION BETWEEN MES & AES	10
GAS, AC AND DC OPERATION	10
REGULATING THE TEMPERATURE	10
TURNING OFF THE REFRIGERATOR	12
STORAGE COMPARTMENTS	12
CONDENSATION CONTROL	13
PRODUCT CARE	14
MAINTENANCE & SERVICE	14
REPLACING THE HEATER	14
PERIODIC MAINTENANCE	14
TROUBLESHOOTING	15
ERROR CODES	15
APPENDIX	
REARVIEW EQUIPMENT	16
WIRING DIAGRAM	17

SYMBOLS

The following symbols are used throughout the manual:



WARNING

Indicates a potentially hazardous situation, which, if not avoided, could result in death or serious injury.



CAUTION

Indicates a potentially hazardous situation, which, if not avoided, may result in minor or moderate injury.

INTRODUCTION

We are pleased that you have chosen this refrigerator and hope you will derive much satisfaction from using it.

The refrigerator is designed for storage of foods and storage of frozen foods and making ice.

The installation and servicing should only be carried out by an authorized/qualified person.

It is important to read through these instructions carefully before using the refrigerator. To ensure good refrigeration and economical operation, the refrigerator must be installed and used as described in these instructions.

Follow the instructions in this manual. The refrigerator is quality guaranteed. However, we are not responsible for any failures caused by improper adjustments and unfavourable installation conditions. Please contact service point or distributor service dept. for assistance.

DATA PLATE

Check the data plate, located inside the refrigerator, to ensure that you have received the right model and that it is suitable for the available gas supply and pressure.

Inlet Pressure: 2.75 kPa

Test Point Pressure: 2.70 kPa

Gas Type: Universal LPG

Nominal Gas Consumption: RM2356 1.10 MJ/H

RM2456 RM2556 1.6 MJ/H

RM4606 RM4806 1.66 MJ/H

Voltage: 230 - 240 volt

The data plate contains e. g. the following details:

Model designation

Product number

Serial number

Since these details will be needed if you have to contact service personnel, it is a good idea to make a note of them here:

CAUTION

Used without the safety alert symbol indicates, a potentially hazardous situation which, if not avoided may result in property damage.



Step-by-step instructions

INSTALLATION INSTRUCTIONS

GENERAL INFORMATION

The installation, servicing and gas installation must be performed by an authorised/qualified person. The refrigerator must be installed in accordance with the manufacturers installation instructions, local gas fitting regulations, municipal building codes, electrical wiring regulations, AS 5601 - Gas Installations' and any other statutory regulations.

PACKAGING

The packaging of this appliance is designed to withstand the transportation from the factory to the point where it will be installed in the recreational vehicle.

Before starting to install the appliance, please, make sure all parts of the packaging have been removed, so there will not be anything left that may come into contact with hot parts of the appliance or obstruct the combustion exhaust gases or the air movement around the cooling unit.

VENTILATION REQUIREMENTS

The installation shall be made in such a manner as to separate the combustion system from the living space of the mobile home or recreational vehicle. Proper installation requires one lower fresh air intake and one upper air outlet vent with a separate gas exhaust outlet.

We recommend fitting the Dometic ventilation system, which is specially developed by Dometic for this purpose. The ventilation kits must be installed and used without modification.

An opening toward the outside at floor level in the refrigerator compartment must be provided for ventilation of heavier-than-air fuel gases. The lower vent of the recommended kits is provided with proper size openings. The flow of combustion and ventilating air must not be obstructed.

The lower side vent provides an adequate access opening for ready serviceability of the burner and control manifold of the refrigerator. This should be centred on the back of the refrigerator.

CLEARANCES

MINIMUM CLEARANCES TO COMBUSTIBLE MATERIAL			
Top	G	0 mm	
Side	K	0 mm	
Bottom	L	0 mm	
Rear	M ¹	25 mm	

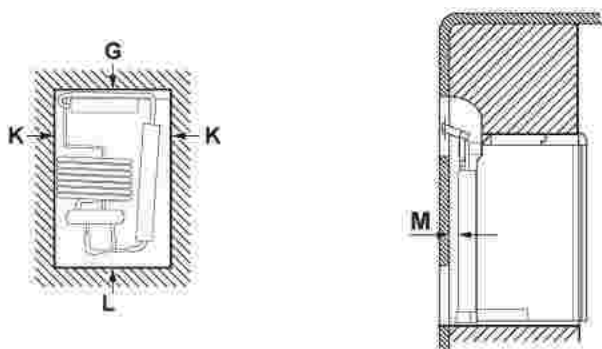

If the lower grille is not at floor level where leaking gas can escape, a 40 mm hole to the outside should be made in the floor of the recess to drain any unburned gas to the outside. Fit the hole with wire mesh and an angled plate to protect it from stones, mud and vermin.

RM2356

MINIMUM VENTILATION REQUIREMENTS

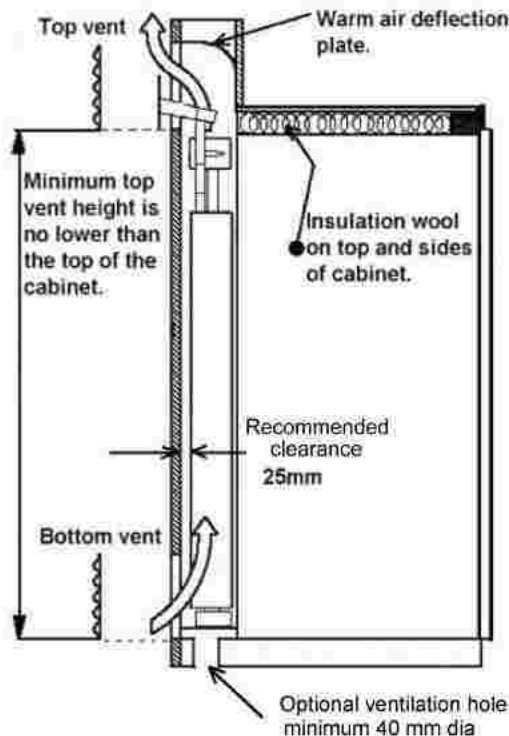

SUGGESTED VENTILATION SYSTEM (NOT INCLUDED)

Ventilation components are:

- 1 X AS1625 vent kit (Top & bottom vents with frames)
- 1 X TP (Includes 1 x Tee piece & 1 x extension; extra extensions may be required depending on the height of refrigerator and vent height. Part number TPX)



AS1625 vent kit



TP Kit



TPX Extension

RM2456 RM2556 RM4606 RM4806

MINIMUM VENTILATION REQUIREMENTS

OPTION 1

LS300 vent and frame cut out required
490mm x 249mm. Each vent has open
area of 667 cm²

Ventilation system not included

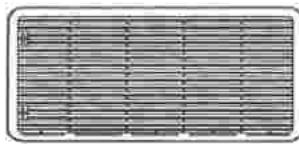

LS300

Gas flue kit
3776



LS300 vent and frame cut out required
490mm x 249mm. Each vent has open
area of 667 cm²

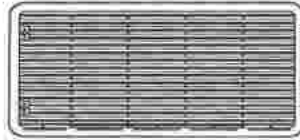

LS300

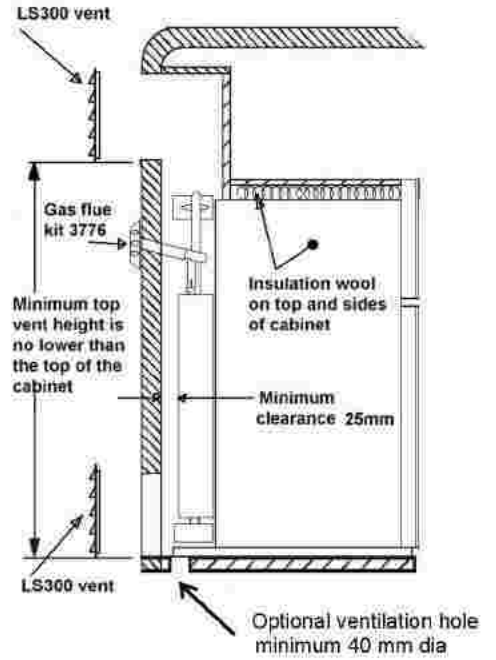

OPTION 2

Roof Cap &
roof base open
ventilation area
of 730 cm²

Ventilation system not included



Gas flue kit
3776



LS300 vent and frame cut out required
490mm x 249mm. Each vent has open
area of 667 cm²

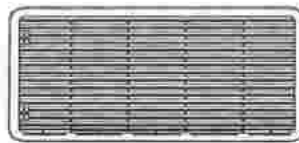

LS300

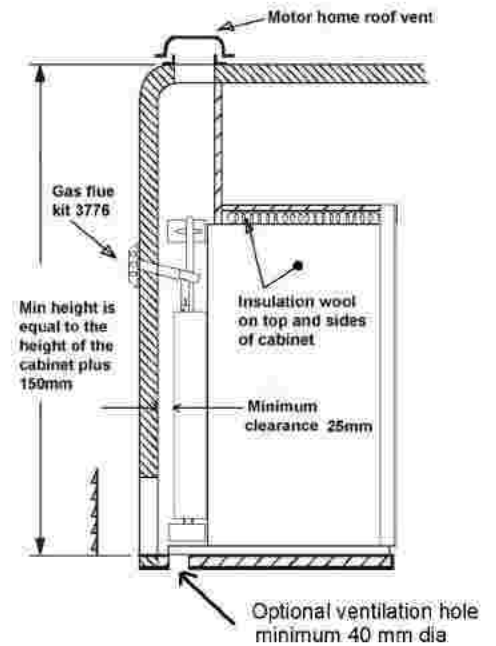

TECHNICAL DATA

	RM2356	RM2456	RM2556	RM4606	RM4806
OVERALL DIMENSIONS					
Height (mm)	766	948	1104	1385	1544
Width (mm)	556	632	632	632	632
Depth incl. cooling unit (mm)	577	627	627	627	627
RECESS DIMENSIONS					
Height (mm)	756	928	1083	1365	1522
Width (mm)	521	607	607	607	607
Depth (mm)	542	610	610	610	610
CAPACITY					
Gross (litres)	95	121	150	186	224
WEIGHT without packaging (kg)					
	29	39	44.5	56.5	58
ELECTRICAL DATA (watt)					
Input 240V	175	195	195	325	325
12V	175	175	175	275	275
UNIVERSAL LP GAS DATA					
Input, max (MJ/h)	1.10	1.16	1.46	1.66	1.68

BUILDING-IN

The refrigerator must not be exposed to radiated heat from hot objects. Excessive heat irradiation impairs performance and leads to increased energy consumption. For this reason the refrigerator should be installed if possible not at the entrance side of the vehicle - normally orientated south and often with an awning which would impair the dispersion of heat and combustion gases from the ventilation openings.

It is not a good practice to install the refrigerator so that the vent openings are covered by the vehicle's entrance door when this is set open. This would reduce the ventilation airflow to the cooling unit and reduce refrigeration performance.

The refrigerator has to be installed in a substantial enclosure and must be level. For information about dimensions, see "TECHNICAL DATA".

The bottom of the enclosure must be horizontal and even so that the refrigerator can be easily pushed into place. It must be sturdy enough to carry the weight of the refrigerator.

A length of sealing strip is applied to the rear surface of the front frame for this purpose, see Fig. 8 / Fig. 9.

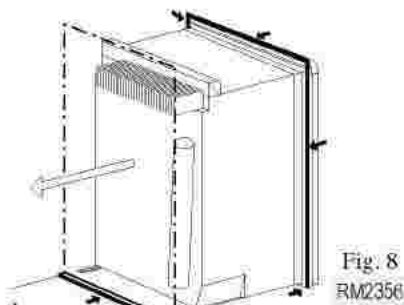

Fig. 8
RM2356

Apply a sealing strip to the foremost floor of the enclosure. The sealing should provide a complete isolation of the appliances combustion system from the vehicle interior.

Make sure that there is a complete seal between the front frame of the refrigerator and top, sides and bottom of the enclosure.

Push the refrigerator into the recess until the sealing strip on the flange seals against the front of the recess, so that the cooling unit is completely sealed off against the interior of the vehicle.

Note! Be careful not to damage the sealing strip when the refrigerator is put in place.

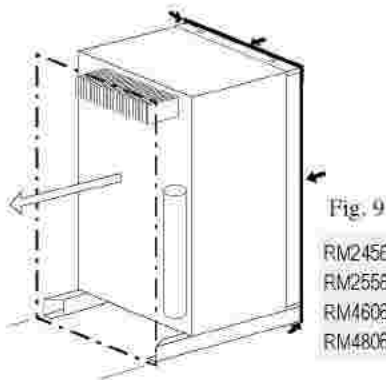

Fig. 9
RM2456
RM2556
RM4606
RM4806

RM2456, RM2556, RM4606 & RM4806

A wood strip must be in place across the upper opening of the enclosure. The top frame of the refrigerator will be anchored to the wood strip with screws.

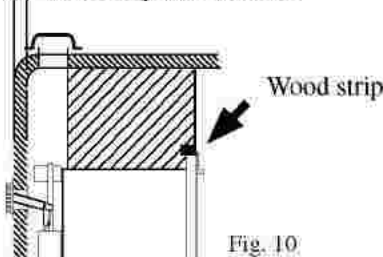

Fig. 10

SECURING THE REFRIGERATOR

For the best cooling performance, when installing refrigerator model:

- RM2356: The installer must block the space between the storage cabinet and the top of the refrigerator.
- RM2456/RM2556/RM4606 & RM4806: The installer must block any space between the counter, storage area or ceiling and top of the refrigerator.

Otherwise the heat will become trapped in this space, making the top of the refrigerator hot, thus reducing the efficiency of the unit.

After the refrigerator is put in place, insuring a combustion seal at the front frame, the refrigerator is to be secured in the enclosure with screws. (These screws are not included.)

Failure to follow the sequence in securing the refrigerator in enclosure can cause leakage between the frame and cabinet.

RM2356

The four screws should be installed in the following order:

1. Four screws installed through the front frame.

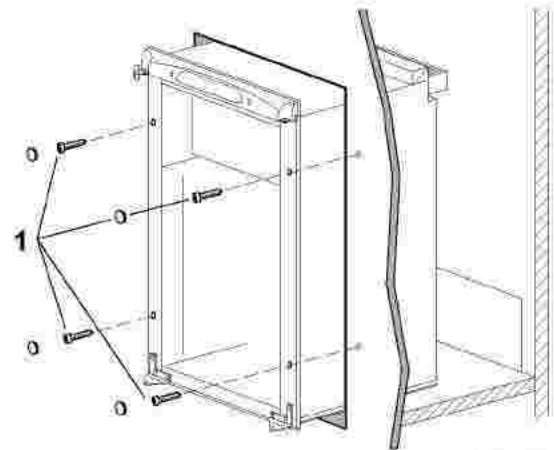

Fig. 11

RM2456, RM2556, RM4606 & RM4806

The six screws have to be installed in the following order:

1. Install two screws into the floor through the front base. (Floor mounted)
When mounting above the floor.
The refrigerator is provided with a lower front strip (shipped as a loose part) which is to be attached after the refrigerator is set into the above floor cutout opening.

- a) Install the lower front strip by sliding it under the bottom hinge plate and swing it into place.

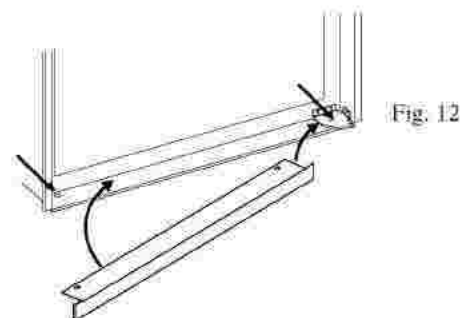

Fig. 12

(The hinge plate can be on the right or left side depending on the door swing.)

- b) Secure the refrigerator and the lower front strip with two screws: One screw through the hinge, and on the opposite side and then, one screw through the lower front strip, see Fig. 13.

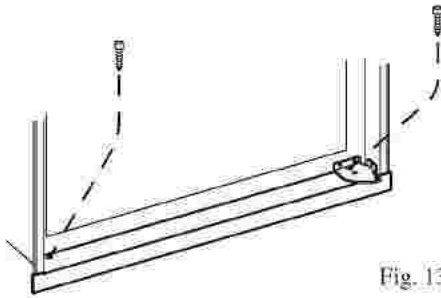

Fig. 13

2. Install two screws in the top frame.

- a) Remove the top decoration panel. Open the door and gently push the tabs out of the hole in the hinge with a flat blade screwdriver, (both sides), see Fig. 14.

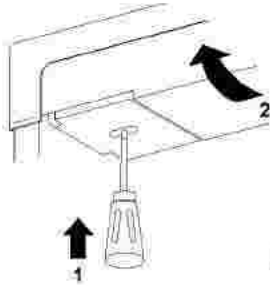

Fig. 14

- b) Carefully tilt the top decoration panel and lift up to remove from top frame. Be careful not to damage the circuit board and wires.
- c) Install the two screws in the top frame. (The holes are accessible from underneath.)
- d) Seal the opening for the screws with aluminium tape.
- e) Replace the top decoration panel. Be careful not to pinch the wires behind the panel. Make sure the tabs snap back into the holes in the hinge plate.

3. Install two screws in the rear base, see Fig. 15.

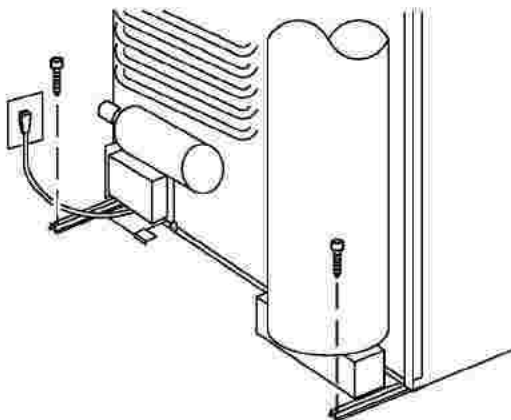

Fig. 15

DRAIN WATER HOSE

A hole must be drilled through flooring, see Fig. 16 / 17.

The installer has to make sure that the hose does not kink when run through the floor. Seal around the hose that goes through the drilled hole.

If a longer hose than supplied is required to get the water to drain outside of the vehicle, the installer will have to supply the extra length of hose.

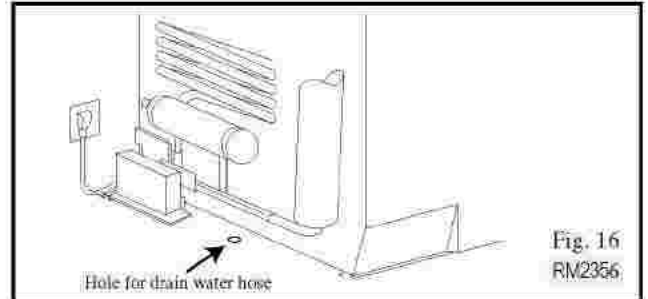

Fig. 16
RM2356

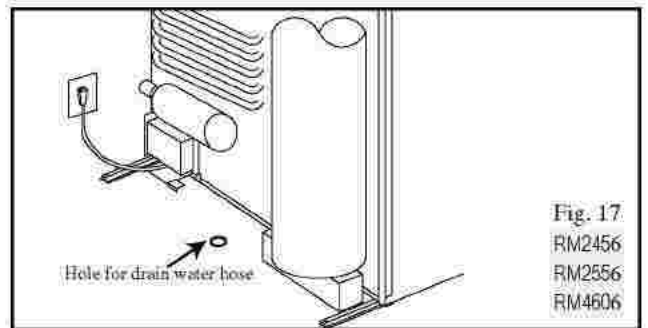
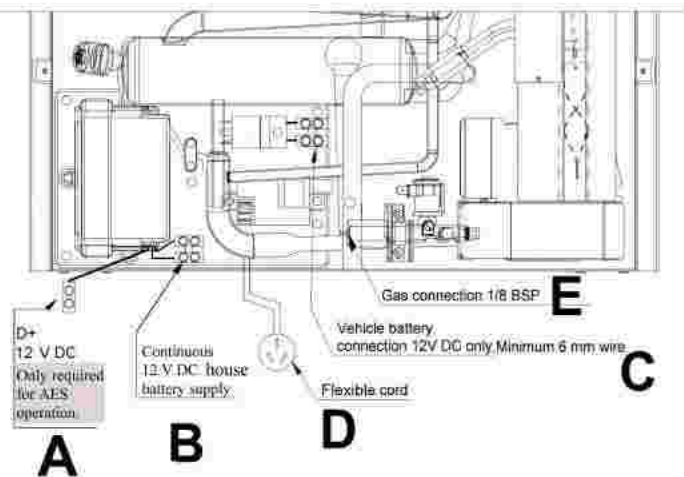

Fig. 17
RM2456
RM2556
RM4606

CONNECTIONS



The refrigerator is equipped with two 12 volt DC connections and one D+ connection (D+ is only required if automatic function has been preset)

- A.** D+ Connection is required if the (AES) control option is preset . The D+ connection is not required if the (MES) control option is preset. (MES is the default mode)
If required this D+ connection must be connected to a 12 V positive DC output from the vehicle charging circuit.
- B.** Connection to permanent 12 volt DC house battery.
- C.** Connection to vehicle battery.
This connection supplies the 12 volt DC heating element.
- D.** AC (240) volt connection.
- E.** Universal gas connection.

UNIVERSAL LP GAS CONNECTION

The gas installation and servicing must be carried out by an authorised person and conform to all relevant local requirements.

The refrigerator is not designed for operation on town gas or natural gas but for operation on universal LP gas, the pressure of which must be 2,75 kPa. Check that this is stated on the data plate. The gas supply system must incorporate an approved gas pressure regulator to maintain a supply pressure of 2,75 kPa.

The supply pipe should be of copper. If other material is used it must be of a type approved for use with continuously operating bottle-gas appliances and have threaded connections throughout.

All connectors etc. should be of a type specifically designed for the type and diameter of the connection pipe used, and screwed joints should be sealed with a joining compound approved for use with bottle-gas.

The gas supply pipe should be connected to the gas valve at the bottom of the refrigerator, by means of a suitable threaded coupling.

The gas valve is furnished with an ISO 7/1 - Rp 1/8 internal pipe thread connection.

In making the connection to the refrigerator, a union gas cock of an approved bottle-gas type must be incorporated in the supply line in a position which is readily accessible to the user. For eventual servicing purposes, the union should be positioned so as not to prevent the refrigerator from being readily withdrawn.

Before leaving, the installer should:

Check all connections for gas leaks with soap and water. DO NOT use a naked flame for detecting leaks! Ignite the burner to ensure correct operation of the controller, burner and ignition. Instruct the user on the correct method of operation. In case the appliance fails to operate correctly after all checks have been carried out, contact the authorised service provider in your area.

AC ELECTRICAL CONNECTION

The electrical installation must be carried out in a proper and durable manner, taking into account all relevant regulations and codes of practice.

For mains voltage operation, it is important that the circuit to and in the caravan is effectively earthed.

The refrigerator is equipped with a three-prong (grounding) plug for your protection against shock hazards and should be plugged directly into a properly grounded threeprong socket. **Note!** Do not cut or remove the grounding prong from this plug.

The free length of the cord is 6 ft. (1,8 m). It is recommended the socket be placed on the left side of the refrigerator (viewed from the rear) and approximately 4-6 inches (100-150 mm) from the floor. This will allow easy accessibility through the vent door.

230-240 V supplies

Check that the voltage stated on the data plate is the same as the main voltage in use (230-240 V). Plug the 230-240 V refrigerator power cord into an easily accessible wall socket. Electrical leads must be routed and secured so that they cannot come into contact with hot or sharp parts of the refrigerator.

DC CONNECTION

12 Volts DC Supplies

The connections are made to the terminal blocks marked 12 volts DC house battery, and 12 volt vehicle battery battery connection.

To avoid a voltage drop, the cross sectional area of the connecting wires between the vehicle battery and the refrigerator must be as those given in the table below.

To ensure safe operation, the positive lead must be fitted with a fuse rated as those given in the table below.

The cross section of the 12 volt DC wires between the continuous 12 volt DC house battery terminal and the battery can be 1.5 mm². The positive lead must be fitted with a fuse rated at 15 amps.

Correct polarity must be observed when connecting to the 12 V DC supply.

Note! Do not use the body or chassis of the vehicle as a substitute for either of the two conductors. Electrical leads must be routed and secured so that they cannot come into contact with hot or sharp parts of the refrigerator.

Do not connect any other electrical equipment or lighting to the refrigerator circuit.

RM2356	Fuse 20 amp	wire size 6 mm
RM2456 & RM2556	Fuse 20 amp	wire size 6 mm
RM4606 & RM4806	Fuse 30 amp	wire size 10 mm

CHANGING DOOR SWING TO OPPOSITE SIDE

(Requires opposite hinge kit)

Hinge conversion kits are included with each refrigerator, follow the instructions included with the conversion kit.

INSTRUCTIONS FOR MOUNTING THE DOOR PANEL RM2356

The refrigerator is normally delivered without door panel.

Before starting the mounting work, check that the panel dimensions are in compliance with those given in the Table and the instructions are read thoroughly.

We recommend to mount the panel on the door before the refrigerator is installed in the enclosure.

When mounting the panel, proceed as follows:

- Remove the screws from the top door cover strip and remove the cover strip by pulling straight upwards.
- Slide the panel from the top of the door into the grooves on the vertical edges of the door sliding downwards until the panel fits into the lower door edge.
- Replace the top decoration strip and fasten with the 3 screws.

RM2356

PANEL DIMENSIONS				
MAX. THICKNESS (4 mm)				
REFR. MODEL TYPE	HEIGHT		WIDTH	
	MAX.	MIN.	MAX.	MIN.
RM2356 mm	710	708	498	496

REFRIGERATOR REMOVAL



1. Before working on the refrigerator, make sure the 230-240 V AC voltage and 12 V DC voltage leads are disconnected.
2. Shut off the gas supply at the ULP gas bottle
3. Disconnect the gas supply line.
Always use a back up wrench when loosening and tightening connections.
4. Cap the gas supply line, loosen the screws anchoring the refrigerator to the enclosure and slide the refrigerator out of the compartment.
5. When replacing the refrigerator make sure that the sealing strips are properly positioned.
6. Replacement is the reverse of removal. Check all connections for gas leaks.

QUICK START OPERATION

⚠ CAUTION

This UES guide must be read in conjunction with the full operating and safety manual before using your refrigerator.

1. Start and stop

Press and hold in for 3 seconds, display will light up or turn off.



2. Check pre set function indicator

AES lit, go to Step 4



MES lit, go to step 3

3. MES Manual Energy Selection

Press MODE to toggle between Gas, AC, or DC operation GO TO STEP 5



4. AES Automatic Energy Selection

Press MODE to toggle between Automatic or Gas operation. got to step 5



Note AES function should only be used when a suitable D+ connection is made to the tow vehicle. See full instructions for details.

5. Set temperature

Press SET to adjust temperature.



OPERATING INSTRUCTIONS

WARNING

1. This appliance is not intended for use by persons (including children) with reduced physical, sensory or mental capabilities, or lack of experience and knowledge, unless they have been given supervision or instruction concerning use of the appliance by a person responsible for their safety.
2. Children should be supervised to ensure that they do not play with the appliance.
3. If the supply cord is damaged, it must be replaced by the manufacturer, its service agent or similarly qualified person in order to avoid hazard.

UNIVERSAL ENERGY SELECTION

IMPORTANT. 12 volt must always be available to supply the control electronics.

This refrigerator is provided with a dual function control system. This refrigerator can be installed and preset to function as an MES (Manual Energy Selection) refrigerator or an AES (Automatic Energy Selection) refrigerator.

When set in MES function, the MES lamp will be lit. While operating in MES function the refrigerator must be manually changed from one fuel to another as required by pressing the Mode button (2) in Fig 1

Each time the Mode button is pressed the fuel selection will move between Gas, 240V AC, and 12 V DC.

Important while operating on 12 V DC it is highly recommended the vehicle engine is running. Operating the refrigerator on 12 V DC will quickly drain the 12 volt battery, therefore the vehicle engine should be running to keep the battery charged.

To operate in AES function (Automatic Energy Selection) the refrigerator must be pre set by the installer. When installed in AES function the AES lamp will be lit on start up. Note the refrigerator can not operate on AES and MES function at the same time.

When set to operate in AES function the refrigerator must be connected via the special D+ connection at the rear of the refrigerator to the DC charging system of the vehicle.

More information is available at www.dometicrvcentre.com.au

The refrigerator can not operate fully in AES function unless the D+ connection has been pre installed by the the installer.

CONTROL PANEL

Fig 1

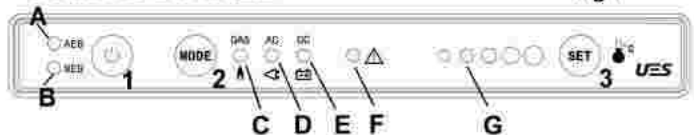

1. ON/OFF Main power button. Press and hold in for 3 seconds to turn on or off.
 2. Mode Button, Press to select fuel source when MES light (B) is lit. Press to select Gas or AES mode when AES light is lit.
 3. Temperature selection press to adjust temperature.
- A. AES function indicator lamp. D. AC operation indicator lamp.
B. MES function indicator lamp. E. DC operation indicator lamp.
C. Gas operation indicator lamp. F. Warning indicator lamp (Gas)
G. Temperature indicator lamps.

Changing between MES & AES function

Changing from MES to AES function and back again can be done at any time, however to use AES function fully the refrigerator must be connected via a D+ wire found on the back of the refrigerator to the vehicle battery charging system.

The differences between MES and AES functions should be fully understood before changing the function.

(See page 11 for details)

OPERATING INSTRUCTIONS (MES)

1. Press and hold the ON/OFF button (1) in for 3 seconds to start or stop the refrigerator. The MES lamp will be lit.
2. With the MES lamp lit press the Mode button (2) to toggle between GAS - AC (240V) - DC (12V) energy source as required.
3. Press the Set button (3) to select the temperature required, larger LED is cooler.

OPERATING INSTRUCTIONS (AES)

(Requires system to be preset to AES function)

1. Press and hold the ON/OFF button (1) in for 3 seconds to start or stop the refrigerator. The AES lamp will be lit.
2. With the AES lamp lit the control will automatically select the optimum available energy source, with the default to AC (240V) if connected.
3. If Gas operation only is preferred press the Mode button (2) once GAS lamp will be lit AES lamp off. Press the button again to return to AES.
4. Press the Set button (3) to select the temperature required, larger LED is cooler.

IMPORTANT

MES operation on 12 volt DC

! CAUTION

Do NOT operate the refrigerator on 12 volt when the vehicle is parked. The amperage draw of the 12-volt DC heating element can discharge a battery in a very short time. The installation of a 12-volt DC operated refrigerator requires a relay to be installed on the tow vehicle or in the caravan. The relay will automatically shut off the 12 volt DC power to the refrigerator when the ignition is turned off. (See fig. 9).

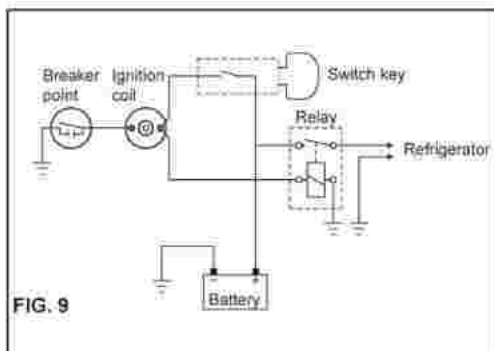

SWITCHING BETWEEN ENERGY SOURCES

When switching from one energy source to another, there are some delays implemented in the AES function. The 15 min. delay between switching off the engine and starting gas mode is intended to delay the starting of gas mode e.g. when stopping at a filling station.

⚠ WARNING

It is not allowed to have a naked flame at a gas filling station. If you are not sure, that your stop is shorter than 15 min., you are advised to set the ON/OFF switch (1) to "OFF", when stopping at a filling station.

ABNORMAL OPERATION

Any of the following are considered to be abnormal operation and may require servicing:

- Yellow tipping of the burner flame.
- Sooting up area surrounding burner.
- Burner not igniting properly.
- Burner failing to remain alight.

In case the appliance fails to operate correctly, contact an authorised Dometic service Centre.

CHANGING BETWEEN MES & AES FUNCTION

The control system function can be set in one of two functions. (MES) Manual Energy Selection the default setting out of the box or (AES) Automatic Energy Selection.

The control function can be changed from one to the other in the following way.



Note: The D+ wire connection must be connected to operate fully in AES function. The MES function will operate with or without the D+ wire connection.

IMPORTANT ! FOR THE INSTALLER

This refrigerator has dual function and may be pre set to the required function (MES) or (AES) function during or after the installation.

1. **MES** operation (**M**anual **E**nergy **S**election) is the default setting. **MES** lamp will be lit at start up.
2. **AES** operation (**A**utomatic **E**nergy **S**election) is optional. If **AES** function is required it must be pre set during installation. **AES** function requires the D+ wire on back of refrigerator to be connected to vehicle charging circuit. Once set (see step 4), the **AES** lamp will be lit at start up.
3. Connect 12 V DC to the control circuit. Press and hold  button for 3 seconds to start the refrigerator. **MES** lamp will remain on.
4. To change the operating function to **AES** or back to **MES**.



Press and hold  and the  buttons in simultaneously for 4 seconds. Control system will move to **AES** function, **AES** lamp will be lit (**MES** off). Repeat this process to move the system back to **MES** function **MES** lamp will be lit (**AES** lamp off).

ABSORPTION REFRIGERATOR SYSTEM

In an absorption refrigerator system, ammonia is liquefied in the finned condenser coil at the top rear of the refrigerator. The liquid ammonia then flows into the evaporator (inside the freezer section) and is exposed to a circulating flow of hydrogen gas, which causes the ammonia to evaporate, creating a cold condition in the freezer.

The tubing in the evaporator section is specifically sloped to provide a continuous movement of liquid ammonia, flowing downward by gravity through this section.

If the refrigerator is operated when it is not level and the vehicle is not moving, liquid ammonia will accumulate in sections of the evaporator tubing. This will slow the circulation of hydrogen and ammonia gas, or in severe cases, completely block it, resulting in a loss of cooling.

Note! Any time the vehicle is parked for several hours with the refrigerator operating, the vehicle must be levelled to prevent this loss of cooling.

When the vehicle is moving, the levelling is not critical, as the rolling and pitching movement of the vehicle will pass to either side of level, keeping the liquid ammonia from accumulating in the evaporator tubing.

WARNING

The sealed cooling system must not be opened.
It contains corroding chemicals under high pressure.

Sodium chromate is used for corrosion protection (less than 2 weight % of the coolant).

TURNING OFF THE REFRIGERATOR

 To shut off the refrigerator press and hold the  button for 3 seconds. All indicator lights will go out.

If the refrigerator will not be in operation for a period of weeks, it should be emptied, defrosted, cleaned and the door left ajar. Use the travel catch to hold in this position. The ice tray should also be dried.

STORAGE COMPARTMENTS

WARNING

Do not store explosive substances in the refrigerator, such as cigarette lighter gas, gasoline, ether or the like.

FOOD STORAGE COMPARTMENT

The food storage compartment is completely closed and unventilated, which is necessary to maintain the required low temperature for food storage. Consequently, foods having a strong odour or those that absorb odours easily should be covered. Vegetables, salads etc. should be covered to retain their crispness.

The coldest positions in the refrigerator are under the cooling fins and at the bottom of the refrigerator. The warmer areas are on the upper door shelves. This should be considered when placing different types of food in the refrigerator.

FROZEN FOOD STORAGE COMPARTMENT

Quick frozen soft fruits and ice cream should be placed in the coldest part of the compartment, which is at the bottom of the aluminium liner. Frozen vegetables, may be stored in any part of the compartment. This compartment is not designed for deep or quickfreezing of food. Meat or fish, whether raw or prepared, can be stored in the frozen food storage compartment provided they are precooled first in the refrigerator. They can be stored about three times longer in the frozen food compartment as compared to the fresh food compartment. To prevent food from drying out, keep it in covered dishes, containers, plastic bags or wrapped in aluminium foil. Ice cubes can be made in the freezer compartment. For faster ice making, the tray should be placed in direct contact with the bottom of the freezer compartment. Ice making is accelerated if the temperature control is turned to the coldest setting. It is a good idea to do this a few hours before the anticipated need for ice, but be sure to turn the thermostat back to normal setting, usually about mid-setting when the ice is formed. Food in the lower compartment may be frozen if the setting is left on the coldest setting.

REMOVING AND REPLACING THE SHELVES

-  1. Remove the shelf locks by inserting the tip of a flat bladed screwdriver into the slot of the locks. Turn the screwdriver counterclockwise and then remove the shelf locks from the wire shelf.



2. Tilt the shelf to one side at an angle while pulling forward.

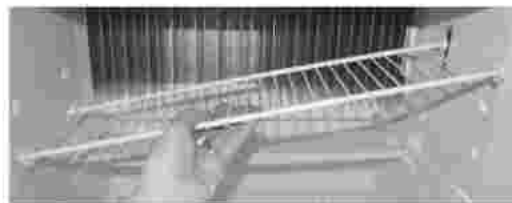

3. Reposition the shelf in the desired location. Insert the ends of the wire shelf on the left-hand side and slide the shelf into the holes on the right-hand side.
4. Slide the plastic plugs into the holes of the wall.
5. Snap the shelf locks onto the wire shelf.



AIRING POSITION CARD

Use the **Airing Position Card** to keep the doors ajar if the refrigerator will not be in use for an extended period of time or put in storage.



RM2456 RM2556 RM4606 RM4806



CONDENSATION CONTROL

HEATING CABLE (RM4606 & RM4806)

During the summer months of high temperatures and humidity, the metal frame between the freezer and fresh food compartments may have water droplets forming. This refrigerator comes standard with a 12V DC heating cable that will evaporate the water droplets when they form.

To have the heating cable on, you position the switch located beneath the control panel to I, see Fig. 2. The heating cable can be left on continuously or only used when temperatures or humidity require it.

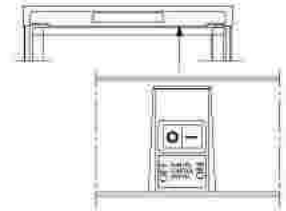

Fig. 2



The heating cable will draw 12V DC power continuously when in the ON (I) position. It should be turned off when a charging source is not available.

REPLACING THE INTERIOR LIGHT

If the interior light in the refrigerator is faulty, you can change the PCB/LED board. To order a replacement PCB/LED board, please contact the Dometic service partner in the respective country.

To Change the PCB/LED board, proceed as follows:

1. Disconnect the power supply to the device.
2. Remove the lamp cover by pressing the side clip 1.
3. Remove the 2 screws.
4. Remove the defective PCB/LED board.
5. Mount the new PCB/LED board.
6. Fasten it with the 2 screws.
7. Attach the lamp cover 2.
8. Reconnect the power supply.

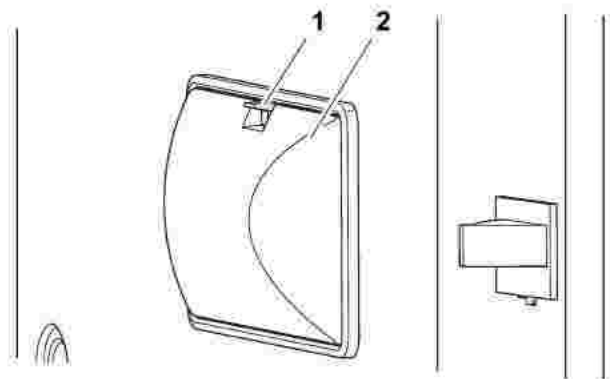

PRODUCT CARE

DEFROSTING

1. Shut off the refrigerator by pressing and holding the  button for 3 seconds, all indicator light will be off.
2. Empty the refrigerator.
3. Leave the cabinet and freezer doors open. Filling the ice tray with hot water and placing it on the freezer shelf can reduce defrosting time.

Defrost water

Defrost water collects in the drip tray and is routed to the outside through the drain tube which should be installed through the floor.

CAUTION

Do not use:

- A knife or an ice pick, or other sharp tools to remove frost from the freezer shelves. It can create a leak in the ammonia system.
 - A hot air blower. Permanent damage could result from warping the metal or plastic parts.
4. When the ice has melted, dry the interior of the refrigerator with a clean cloth.
 5. Ensure the drip tray is in its original position.
 6. Replace all food and set the thermostat to "MAX" for a few hours. Then reset the thermostat to the desired setting, usually at mid-setting.

CLEANING THE REFRIGERATOR

Always keep the refrigerator clean. Cleaning the refrigerator is usually done after it is defrosted or put into storage. To clean the interior liner of the refrigerator, use lukewarm weak soda solution. Use only warm water to clean the finned evaporator, gasket, ice tray and shelves.

Note! Never use strong chemicals or abrasives to clean these parts, as the protective surfaces will be damaged.

It is important to keep the area at the back of the refrigerator clean. Check the lower vent, upper vent and area between these openings for any obstructions such as bird/insect nests, spider webs, etc. Clean the coils on the back of the refrigerator. Use a soft bristled brush to dust off the coils. Keep the refrigerator area free from combustible material, gasoline and other flammable vapours or liquids.

MAINTENANCE & SERVICE

Service and maintenance must be done on a regular schedule to keep the refrigerator operating properly, efficiently and safely. The service should only be performed by an authorised person.

This appliance must be serviced by an authorised person. We recommend that an authorised service technician checks the refrigerator once a year. The "Installation and operating installations manual" should always be available.

Ensure the gas safety shut-off valve is working properly. Make sure that the ventilation openings are unobstructed. See to it that the burner is clean and free from combustible material. All connections in the LP gas system should be checked for gas leaks. Connections can be tested for leaks using a soap solution. **Do not use a naked flame!** If there is any suspicion of damage, call for an authorised service technician.

SERVICE AND SPARE PARTS

Service and spare parts are obtainable from your dealer or Dometic - consult the telephone directory.

REPLACING THE HEATER

The refrigerator is equipped with two electrical heaters, one for 230-240 VAC and one for 12 V DC.

To replace the heater proceed as follows:

1. Unplug the refrigerator power cord from the 230-240 volt AC outlet. Disconnect the 12 V DC power to the refrigerator.
2. Remove the refrigerator from the enclosure.
3. Disconnect the heater leads.
4. With a pair of pliers, unfold the lug holding the lid of the boiler casing and open the lid.
5. Remove some insulation wool so that the heater is accessible.
6. Turn and lift the heater out of its pocket.
7. Fit the new heater into the pocket.
8. Reconnect the heater leads at the top.
9. Put back the insulation and close the lid of the boiler.
10. Reinstall the refrigerator in the enclosure.
11. Check all connections for gas leaks.
12. A qualified gas fitter should be employed
13. Connect 230-240V power cord to the outlet
14. Reconnect or turn on the 12 V DC power.

PERIODIC MAINTENANCE

This work should be made by a qualified service man.

CHECKING THE CONNECTIONS

Check all connections in the ULP gas system (at the back of the refrigerator) for gas leaks. The ULP gas supply must be turned on. Apply a non-corrosive bubble solution to all ULP gas connections. The appearance of bubbles indicates a leak and should be repaired immediately by a qualified gas fitter

CHECKING THE ULP GAS PRESSURE

The ULP gas pressure should be checked and the main regulator readjusted if pressure is incorrect. The correct operating pressure is 2,7 kPa. The correct place to measure the ULP gas pressure is at the test port just ahead of the burner jet.

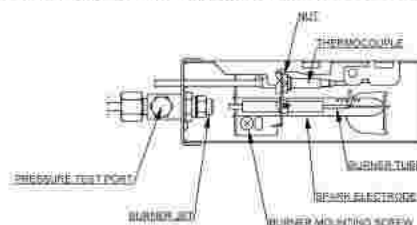

CLEANING THE FLUE AND BURNER

Maintenance work should be made by a qualified service man.

Inspect the flue baffle. It should be reasonably clean and free of soot. Heavy soot formation indicates improper functioning of the burner.

The flue and burner both require cleaning in the following manner:

1. Unplug the refrigerator power cord from the 230-240 V AC outlet. Disconnect or shut off the 12 V DC power to the refrigerator.
2. Close the gas valve at the gas bottle and at the refrigerator.
3. Remove cover from the burner housing.
4. Disconnect the wire from the high voltage electrode.
5. Remove the burner mounting screw and remove the burner assembly.
6. Lift out the wire and flue baffle from the top of flue tube.
7. Clean the flue from the top using a flue brush. Blowing compressed air into the flue will not properly clean soot and scale out of the flue tube.
8. Replace the flue baffle.
9. Clean burner tube with a brush. Blow out burner with compressed air.

WARNING

Do not use a wire or pin when cleaning the burner jet as damage can occur to the precision opening. This can cause damage to the refrigerator or create a fire hazard.

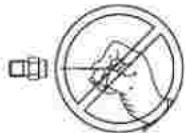

10. Before removing burner jet, clean burner area of soot and scale that fell out of flue tube.
11. Remove the burner jet. Soak the jet in wood alcohol and blow out with compressed air. Reinstall and tighten burner jet.
12. Reinstall burner, being careful that the end of the burner fits into the slot on the burner bracket.
13. Check to make sure the slots are centred under the flue tube and that the thermocouple is positioned properly (tip of thermocouple extends over two slots of burner). Note that the colour of the flame should be clear blue over the slots of the burner.

Clear blue colour of flame

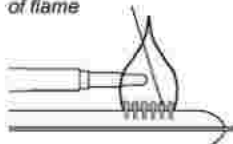

14. Be sure to reconnect the wire to high voltage electrode. Check the electrode for proper location and gap.

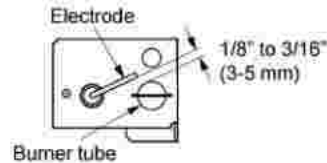

15. Open the gas valve at the bottle and at the refrigerator.
16. Check all fittings for leaks with soapy water.
17. Connect 230-240 volt power cord to the outlet and reconnect the 12 V DC power.
18. Check ULP gas safety shutoff.

TROUBLESHOOTING

REFRIGERATOR DOES NOT COOL PROPERLY















- Burner jet clogged. (gas operation)
- Check level of refrigerator.
- Ventilation problem
- Heavy frost buildup on evaporator fins.
- Improperly set thermostat.
- ULP gas pressure low at burner. Should be 2.75 kPa

FREEZER TEMPERATURE TOO WARM DURING COLD WEATHER

- Change the fresh food area temperature to a colder setting.

FLASHING ERROR CODES

Temperature indicator LEDs will flash if a know error is found.  Means corresponding LED will flash.

	1	2	3	4	5
AC power not present.					
DC power not present.					
NTC sensor failure.					
Input voltage error.					
Communication error.					

APPENDIX A - REARVIEW EQUIPMENT

RM2356

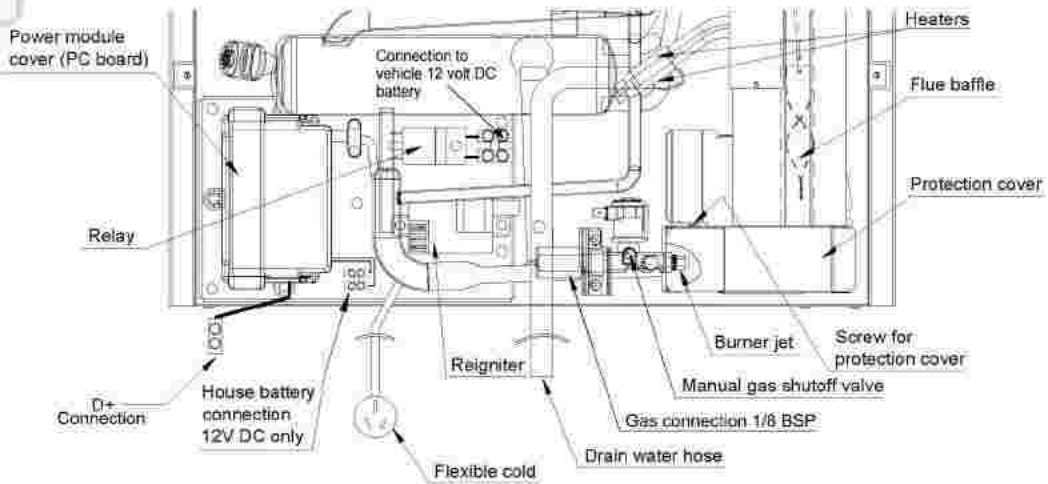

RM2456/RM2556

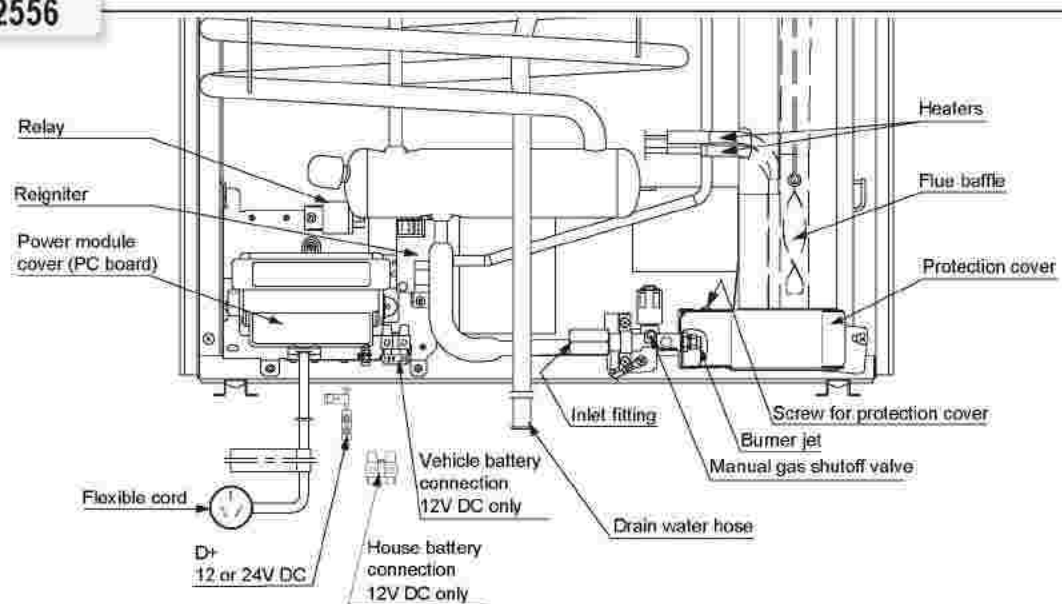

RM4606/RM4806

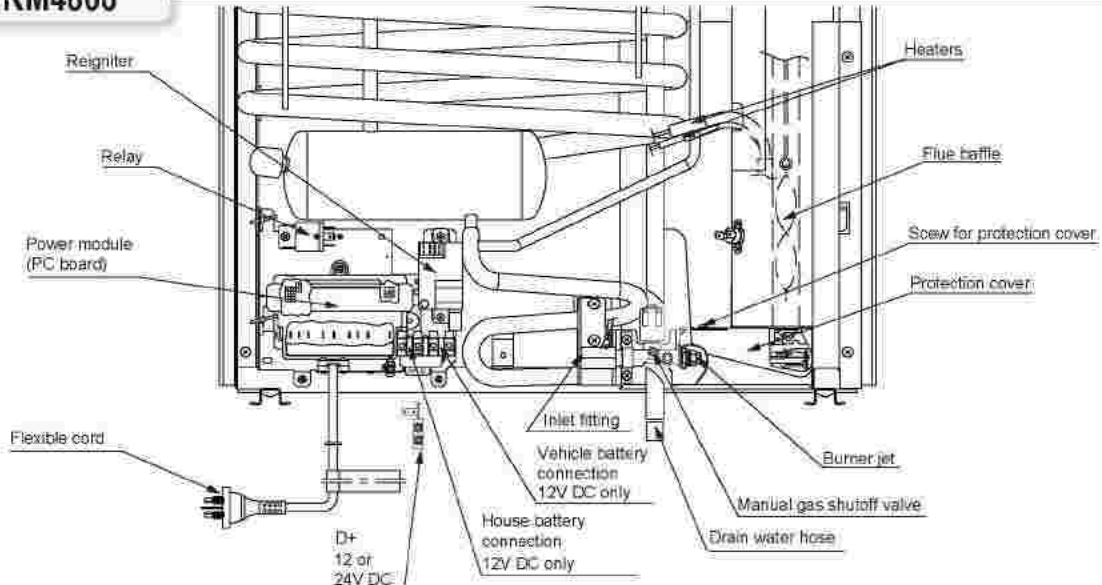

APPENDIX B - WIRING DIAGRAM

RM2356 RM2456/RM2556

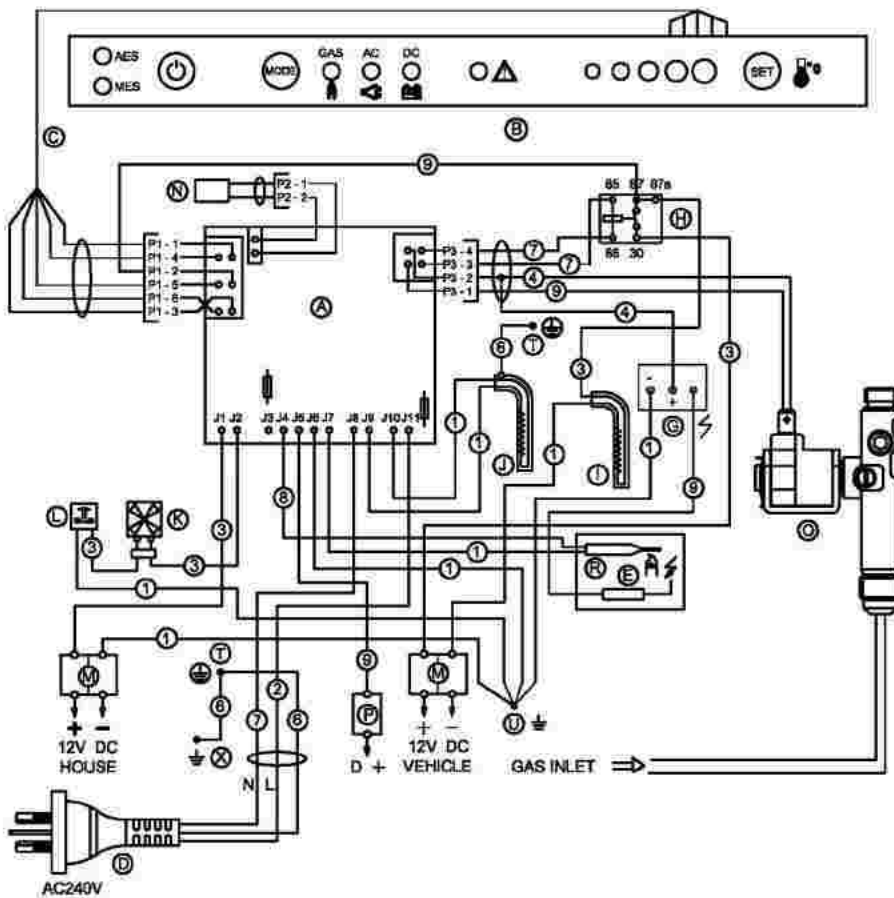

- (A) MAIN BOARD
 - (B) DISPLAY BOARD
 - (C) WIRING HARNESS
 - (D) POWER CORD
 - (E) ELECTROD
 - (G) REIGNITOR
 - (H) RELAY
 - (I) DC12V HEATER
 - (J) AC240V HEATER
 - (K) FAN
 - (L) THERMOFUSE
 - (M) TERMINAL BLOCK
 - (N) NTC THERMISTOR
 - (O) SOLENOID VALVE
 - (P) TERMINAL BLOCK (D+)
 - (R) THERMOCOUPLE
 - (T) PROTECTIVE EARTH
 - (U) CHASSIS GROUND
 - (X) RETAINER
- ① BLACK
 - ② BROWN
 - ③ RED
 - ④ YELLOW
 - ⑤ GREEN
 - ⑥ GREEN/YELLOW
 - ⑦ BLUE
 - ⑧ GREY
 - ⑨ WHITE

RM4606/RM4806

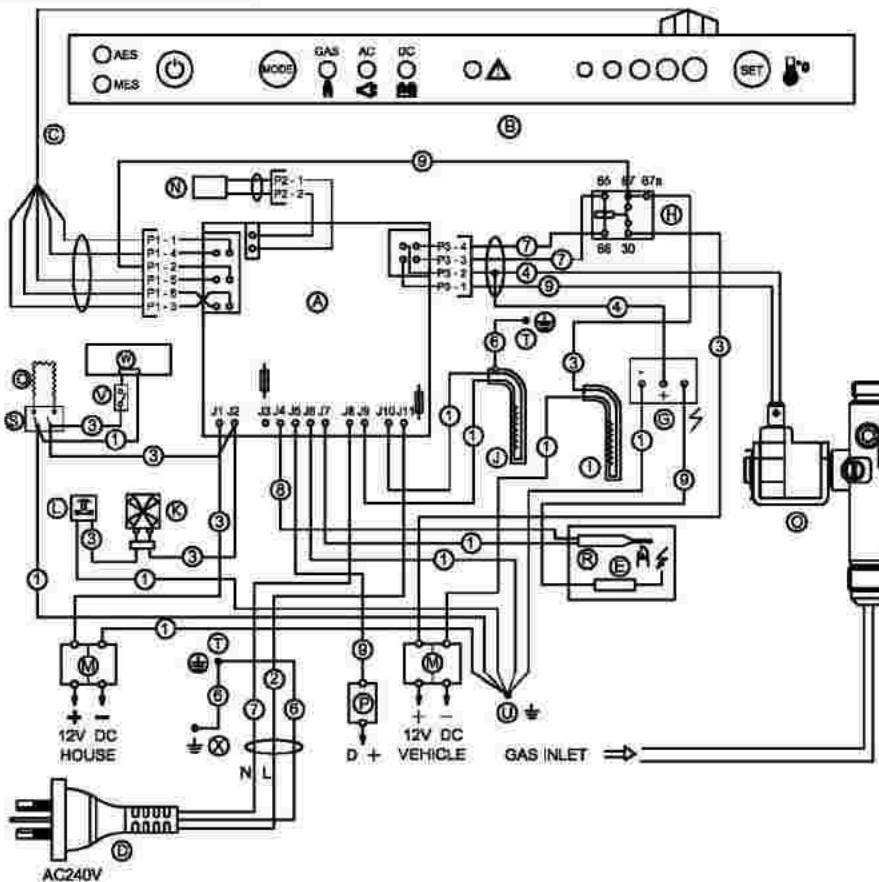

- (A) MAIN BOARD
 - (B) DISPLAY BOARD
 - (C) WIRING HARNESS
 - (D) POWER CORD
 - (E) ELECTROD
 - (G) REIGNITOR
 - (H) RELAY
 - (I) DC12V HEATER
 - (J) AC240V HEATER
 - (K) FAN
 - (L) THERMOFUSE
 - (M) TERMINAL BLOCK
 - (N) NTC THERMISTOR
 - (O) SOLENOID VALVE
 - (P) TERMINAL BLOCK (D+)
 - (Q) HEATING CABLE
 - (R) THERMOCOUPLE
 - (S) SWITCH H.C.
 - (V) LIGHT SWITCH
 - (W) LED LAMP
 - (T) PROTECTIVE EARTH
 - (U) CHASSIS GROUND
 - (X) RETAINER
- ① BLACK
 - ② BROWN
 - ③ RED
 - ④ YELLOW
 - ⑤ GREEN
 - ⑥ GREEN/YELLOW
 - ⑦ BLUE
 - ⑧ GREY
 - ⑨ WHITE

